



Our Product Range -
Sensor Technology, Signal Processing, Visualisation



Content

Aim for success - with NORIS	03
We supply everything from one source	04
SENSORS in detail	07
Speed sensors (non-contacting)	08
Temperature sensors	10
Cable harnesses	12
Speed pick-ups (mech. connected)	14
Pressure transducers	15
Rotation angle pick-ups	16
Tachogenerators	17
SIGNAL PROCESSING in detail	19
Measuring transducers and limit value switches	20
Multifunctional devices	22
VISUALISATION in detail	25
Analogue indicators	26

Aim for success – with NORIS

For us reliability is key

Our products are designed to reliably operate for years and years under the most extreme environmental conditions in safety applications. We constantly ask ourselves the question: „What is REALLY required in order to offer our customers the functions they really need?“

Through a large number of projects in the most diverse sectors we have been able to prove that:

- Our sophisticated products and concepts have a proven record of success under extreme conditions in numerous applications
- We know what our customers really need
- Our well-established delivery loyalty and reliable service provide our customers with the support they expect (in many cases more than 30 years)
- Individual solutions of the highest quality do not need to be costly

Reliability and trust founded on almost 90 years of experience

We've been there from the very beginning. Experience is our greatest asset. For almost 90 years we have been successfully developing products and solutions in the fields of sensor technology, signal processing and visualisation. We leave nothing to chance – that's why our in-company development and production ensures everything comes from under one roof.

Reap the profits from our greatest asset:

- Comprehensive customer support based on long-standing cooperation
- Experienced staff and their quality awareness
- Perfect service worldwide
- DIN EN ISO 9001:2008 certified quality and transparency

We offer complete solutions

We take a holistic approach in solving your specific tasks. Even as early as the design stage our products are developed to perfectly complement each other. This gives rise to a module concept on system level that enables us to create complete measurement and signal chains from our products. Furthermore, even after your purchase we stay involved in your project by supplying spare parts as required as well as updating and expanding your system solution.

Your benefits at a glance:

- Maximum product compatibility and flexibility
- Cost-effective solutions based on a modular system
- Reliability ensured by perfectly matched components
- Guaranteed availability of devices and spare parts over many years

Our areas of expertise

Our customers mainly come from shipbuilding, transport technology, mechanical engineering and industry. You will find our products and solutions in motors, engines, gearboxes, devices and machines worldwide.

We would like to include you among our many satisfied customers!

Shipbuilding

Railway industries

Industry

Machinery
and equipment

Commercial vehicles

Your future is our future

To offer state-of-the-art products featuring ultramodern technology at fair and attractive prices now and in the future, we constantly strive to:

- Integrate the latest technologies in our products
- Test new developments under the toughest conditions
- Create individual solutions for our customers
- Focus on the ever growing demands when developing new devices
- Be one step ahead of currently applicable standards

We supply everything from one source

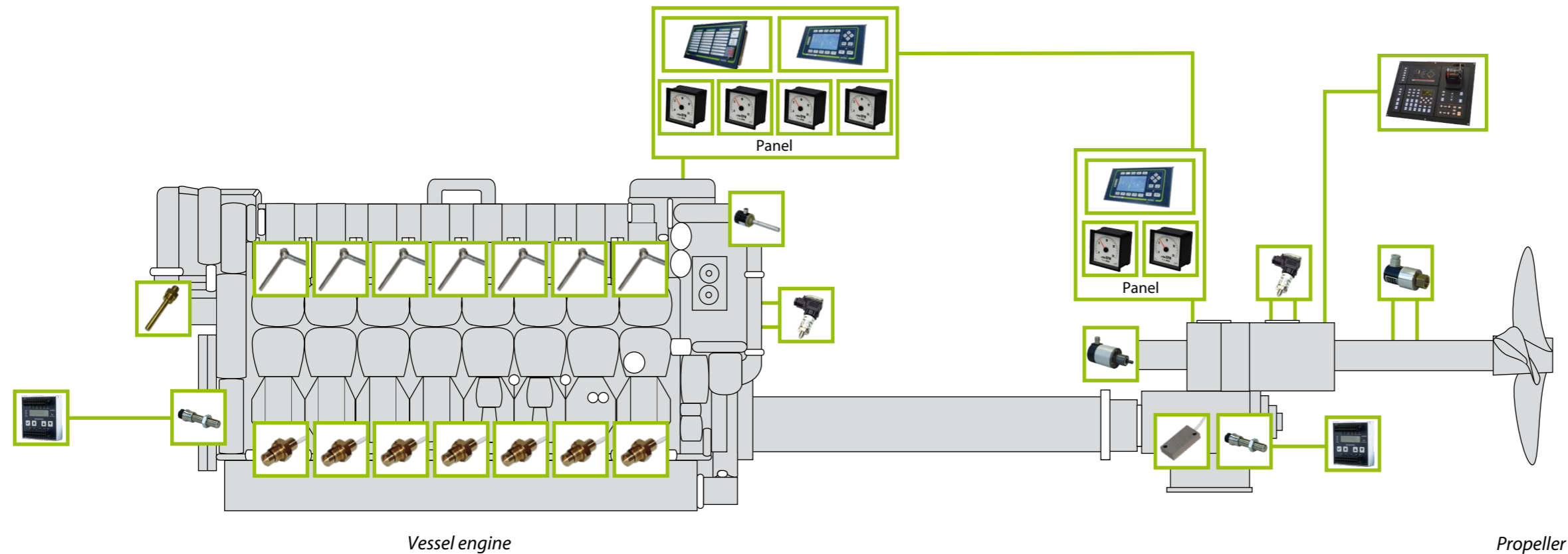
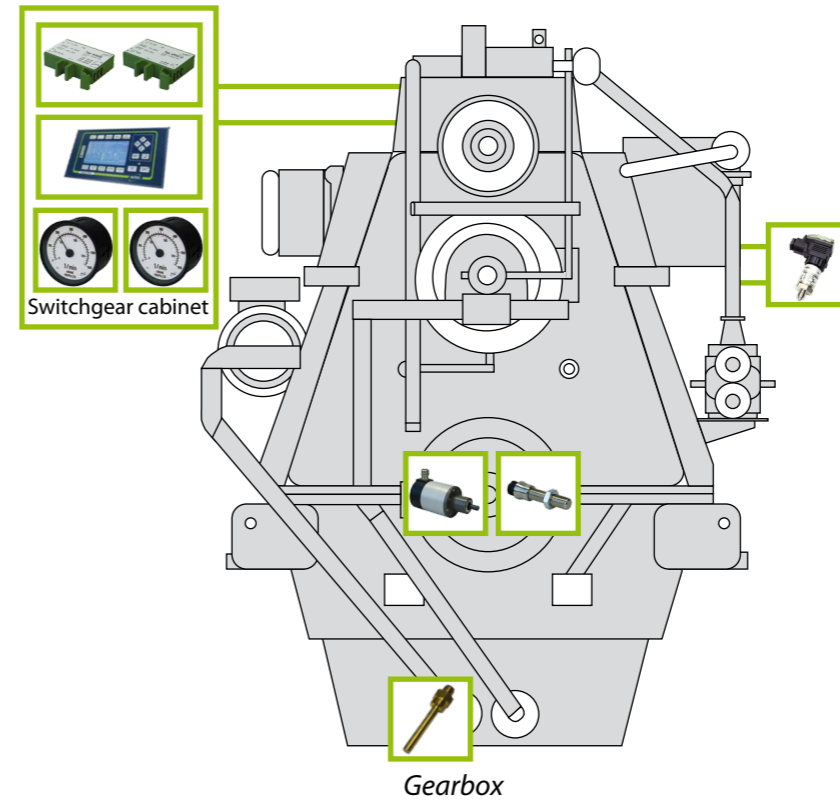
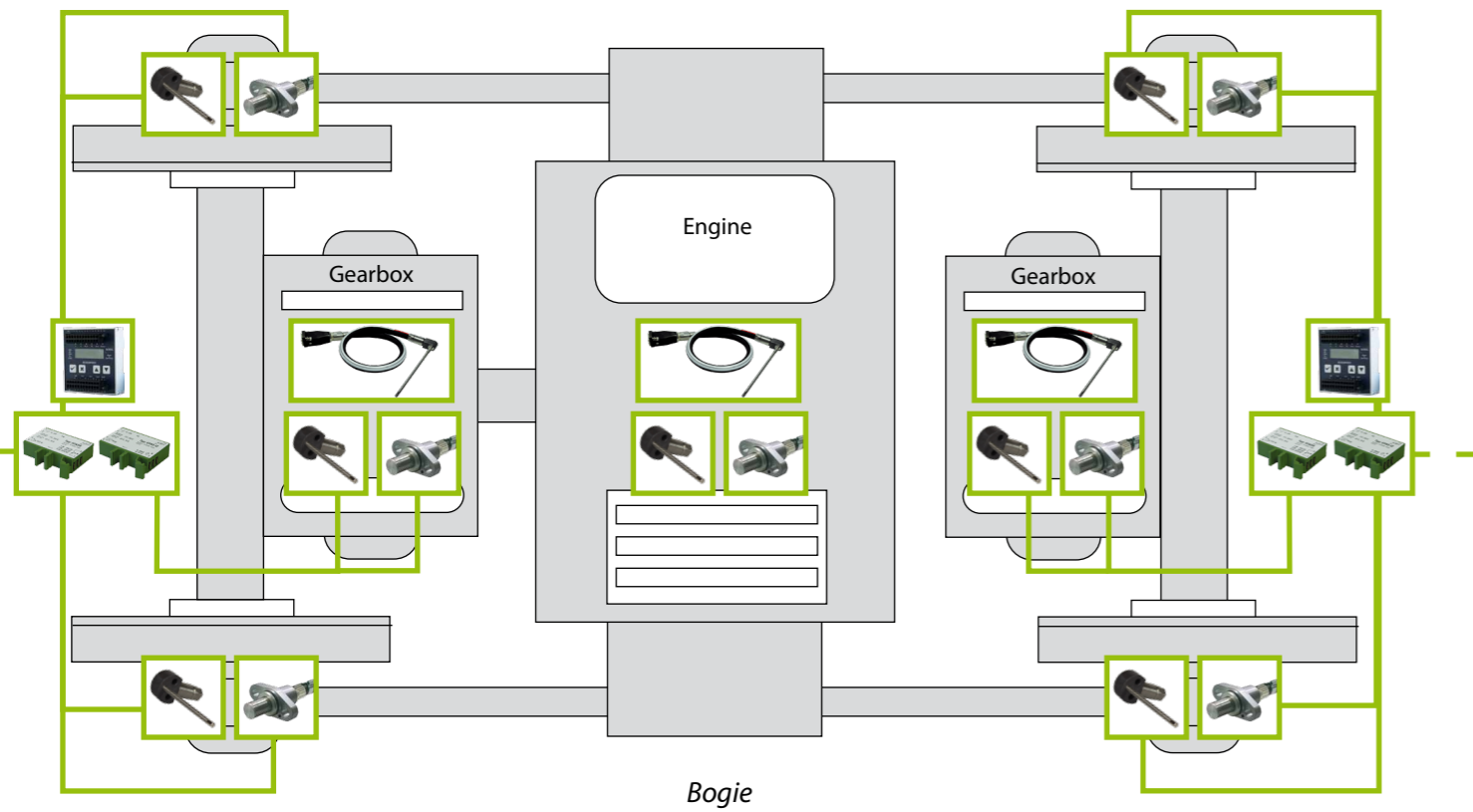

Sensors

- Speed sensors
- Temperature sensors
- Cable harnesses
- Pressure transducers
- Rotation angle pick-ups
- Tachogenerators

Signal processing

- Measuring transducers and limit value switches
- Multifunctional devices

Visualisation

- Analogue indicators

Automation systems

- Ship remote controls
- LOP
- Engine Safety Systems

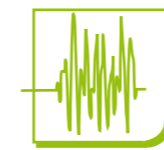

Sensors in detail

Whether monitoring the speed of a ship's engine or railway gearbox, monitoring temperature of bearings in drive units, recording pressures in hydraulic system or registering the position of a ship's rudder, irrespective of how varied these applications may be they have three things in common:

- In view of their harsh ambient conditions, they place exceptional mechanical and electrical demands on sensor systems
- They are all associated with safety in their respective applications
- We offer the right solutions

Sensors for special applications

Designers are often faced with the problem of standard sensors not fitting in the concept. This is either due to the mechanical design or the electrical parameters. Such cases can quickly become complicated and expensive. We have made it our aim to get round this problem:

The modular design of our sensors enables us to simply turn a standard product into an affordable, customer-specific product. You specify the requirements and general conditions and together we work out the solution. Just ask us!

NORIS sensors of the future

To strengthen our market position we continuously strive to expand our product portfolio by state-of-the-art products that meet market requirements. In the field of sensor technology we are currently (and will continue in the future) working on:

"Intelligent" field devices

In future we will develop our tried and tested sensors beyond the task of pure signal acquisition into "intelligent" field devices, which can perform simple signal evaluation tasks and feature corresponding bus connections.

Application-specific combination sensors

It is often necessary to register several measured variables at one point in a machine (especially in the area of condition monitoring). This is why we will be focussing our efforts on the development of combination sensors. This will not only reduce the number of required sensors but also minimise the susceptibility of the entire system to interference, with the added advantage of reducing the complexity of downstream components.

Standard sensors

Speed sensors
(non-contacting)

Temperature sensors

Cable harnesses

Speed pick-ups
(mech. connected)

Pressure transducers

Rotation angle pick-ups

Tachogenerators



© Siemens AG

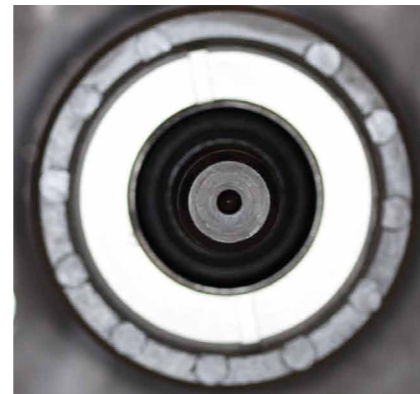
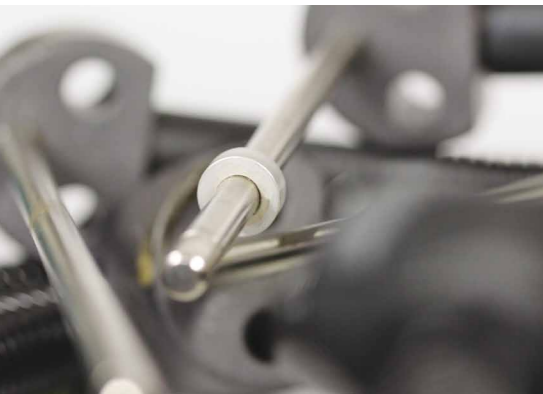

© J. J. Sietas

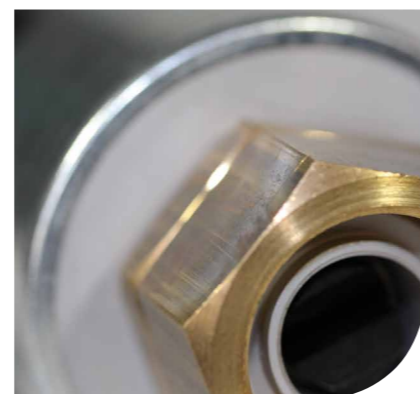



Speed sensors

Today, non-contacting speed sensors are predominantly used to monitor the speed of machines, engines or motors. These sensors register the rotation of toothed wheels made from ferromagnetic metals such as iron and steel but also aluminium. Depending on requirements, various measurement principles (see table) can be used (**inductive-magnetic principle, difference-hall-effect principle, eddy current principle**). So-called impulse bands can also be fitted to enable non-contacting signal acquisition of smooth shafts. Furthermore, any movement of metal parts or changes in their geometry can be measured with these sensors.

Functional principle

The rotary speed registered by the sensor is converted by a signal amplifier into an electrical squarewave signal with a frequency that is directly proportional to the speed. The signal can be evaluated or transformed by a downstream signal processing component.

	Inductive-magnetic principle; FAJ	Difference-hall effect principle; FAH	Eddy current principle
Signal acquisition	The sensor element consists of a permanent magnet and a coil. Toothed wheels or impulse bands induce a voltage in the sensor coil.	The sensor element consists of a permanent magnet and a differential Hall element. Toothed wheels or impulse bands change the Hall voltage.	The sensor element consists of excitation and evaluation coils. Toothed wheels or impulse bands induce an eddy current in the evaluation coils.
Frequency	5 ... 10,000 Hz	Approx. 0 ... 20,000 Hz	0 ... 10,000 Hz (optionally up to 20,000 Hz)
Module	≥ m2 (restricted m1)	≥ m2 (restricted m1)	≥ m1
Distance	Recommended: 1 ... 3 mm (5 mm and more possible)	Recommended: 1 ... 2 mm (max. 3 mm)	Recommended: 0.5 ... 1 mm (max. 1.5 mm)
Installation mode	Direction-insensitive	Direction-sensitive	Direction-sensitive
Applications and special features	Standard applications <ul style="list-style-type: none"> • Easy to use • Large error tolerance • Large temperature range 	Standard and special applications <ul style="list-style-type: none"> • Can be used at frequencies below 5 Hz • Differential principle: <ul style="list-style-type: none"> - Immune to radial toothed wheel vibration (e.g. bearing play, concentricity error) - Reduction of interference of external magnetic alternating fields (e.g. electric motor magnetic fields) 	Special applications <ul style="list-style-type: none"> • Can be used at frequencies below 5 Hz • Scanning of aluminium, brass and stainless steel <ul style="list-style-type: none"> - Reduced weight • Immune to ferrous metal dust and chips*) <ul style="list-style-type: none"> - Use in immediate vicinity of brake dust - Use in "ferrous" environments - Low maintenance

*) Due to the fact that this measuring principle involves no permanent magnets, the sensor head will not become clogged with metal chips during operation. This reduces the maintenance intervals.

Main features

Our speed sensors exhibit the following properties:

Mechanics

- Sturdy design with threaded rod or flange connection
- Different housing materials (e.g. brass, stainless steel or aluminium)
- Different connectors, threads and rod lengths
- Test prod completely protected by metal enclosed end face, resistant to splash oil and lubricants even at high temperatures
- Protection class of housing - IP66/IP67 (IP68 on request)
- Connection lines protected by unique protective tube design - see information on cable harnesses (page 12)

Special applications

Multichannel sensors

We equip our speed sensors for different combinations of electrical output signals. In addition to optimum adaptation of sensors to a downstream evaluation unit, this makes it possible to detect direction of rotation or provide maximum security by use of redundant signal outputs.

- Phase offset of two signals by 90°
- Additional inverted signals
- Woodward regulator ($U_{OUT} = \pm \frac{1}{2} \times U_B$)
- Two galvanically isolated sensor systems in one housing
- Integrated directional rotation recognition
- Integrated standstill monitoring
- Galvanically isolated parallel output for individual control tasks

High temperature applications

For such applications, we offer sensors that operate based on the inductive-magnetic measuring principle. These devices are available with a signal amplifier for a maximum operating temperature of up to 160 °C. The special design of the head unit with integrated insulation element thermally decouples the electronics of the signal amplifier from the sensor tip. This guarantees a long service life even under difficult thermal conditions. These devices are available without a signal amplifier for a maximum operating temperature of up to 220 °C.



Electronics

- Status shown by status LEDs
- Interference-immune output signal
- Inputs and outputs protected against polarity reversal and overloading
- Matching measuring transducers and limit value switches available or already integrated

Environmental influences

- High EMC protection conforming to branch-specific standards
- Large operating temperature range -40 °C ... +125 °C
- Test prod temperature up to +175 °C
- Outstanding resistance to vibration and shock

Temperature sensors

Nothing is more varied in the world of sensors than the structural shape. Although there are only a few measuring methods, the scope of applications and therefore the variety of structural applications are great. Our temperature sensors are specifically designed for transport technology and shipbuilding. We therefore construct our sensors according to the structural shapes required in these sectors. In vehicle engineering our sensors are used to monitor bearing temperatures in the underfloor area as well as for engine and gearbox monitoring. On the other hand, in shipbuilding applications the sensors are used to measure exhaust gas, oil, coolant and bearing temperatures. Our product range also includes stern tube sensors. We would be pleased to assist you in selecting which physical measuring method and which structural shape are best suited for your requirements.



Functional principle

The sensor element converts a measured temperature value into a characteristic curve corresponding to resistance or into an equivalent thermoelectric voltage. These parameters can be tapped off at the two sensor connections.

Main properties

Housing, material and dimensions

When selecting the sensor housing, it is necessary to take into account various requirements such as extreme low and high temperatures, condensation, aggressive substances, oil, corrosion and much more.

- Brass (inexpensively priced and responsive)
- Stainless steel (resistant to aggressive substances)
- CuNiFer (specially for salt water applications)
- Different sensor length and immersion depths
- Housing up to IP68

Electronics and connection

- Overvoltage and overload protection, short-circuit-proof
- Connection via plug (IP68) or open cable end

Cable protection

Our sensors come with different types of protective cable tubing corresponding to the required protection class or protection stipulations (e.g. stone or ice impact in transport technology) (see page 12/13).

	NTC (thermistors); TAH	Pt100 / Pt1000 (resistance thermometers); TAP / TAPT	Thermocouples; TATJ / TATK
Signal acquisition	The resistance of NTC thermistors decreases exponentially as temperature increases.	The relationship between temperature and resistance is defined in DIN 43760 – approximately linear measuring range.	The thermocouple (two metals) delivers a thermoelectric voltage. This measuring method is more intricate than that of NTC or Pt100/Pt1000.
Scope of application	Low to medium temperatures	Very low to higher temperatures	Higher to extremely high temperatures
Temperature range	0 °C ... 70 °C, 40 °C ... 120 °C	-40 °C ... 200 °C	Up to 800 °C
Connection line	Negligible	The line resistance influences the measurement, line compensation is therefore necessary for 2-conductor sensors.	The line must be protected from electrical interference. An equalising conductor is required.
Accuracy	• Standard	• Exceptionally high measuring accuracy possible • High long-term stability	• High measuring accuracy
Multiple sensors	Yes	Yes	Yes
Evaluators	Yes (not standard)	Yes	Yes
Applications and special features	Various NTC elements available	2-conductor, 3-conductor and 4-conductor sensors available	Different types (J, K) available

Special designs

Temperature sensor with built-in measuring transducer

Our product range includes temperature transducers covering the temperature range from -40 °C to 200 °C. The temperature is registered by a Pt100 sensor element and converted into analogue, interference-immune industrial standard signals (U/I) by an integrated measuring amplifier directly at the measuring point. LEDs indicate the operating status of the measuring transducer.

Multichannel sensors

In transport technology, there is an ever increasing demand for redundant, galvanically isolated systems. Our temperature sensors can therefore be equipped with two separate Pt100 sensor elements in one housing.

Customer-specific sensors

Building on various types of sensors as a basis, it is possible to design effective customer-specific solutions. By specifying the material, sensor length, cable length,

connection type and thread, the sensors are manufactured to suit specific requirements.

Protection tubes

Sensors are often installed together with protection tubes to make it possible to replace them during operation (e.g. on motors). We can supply you with suitable protection tubes in different materials and dimensions.

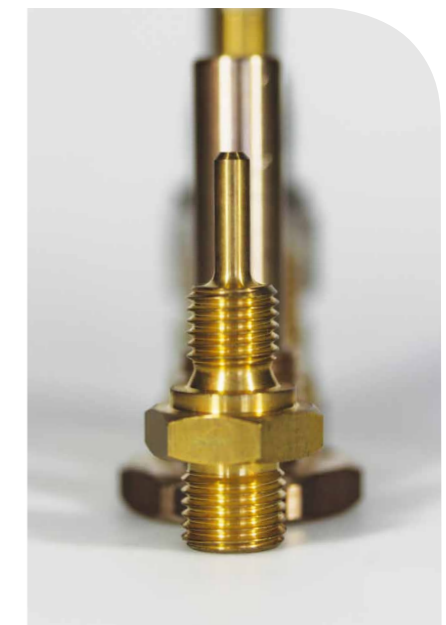

Cable harnesses

Thanks to the reliability and robustness of our products, for years NORIS has been a leading speed and temperature sensor manufacturer in the transport technology sector. A key point for us is to guarantee the effectiveness of our products under extreme conditions. Great demands are placed on sensors and wiring particularly in the underfloor area. While sensors are mostly installed with mechanical protection, the cables are often exposed to direct impact of stones and ice and therefore represent a weak point. For this reason, on customer request, we supply our sensors with protective tubing.

Customer-specific cable harnesses

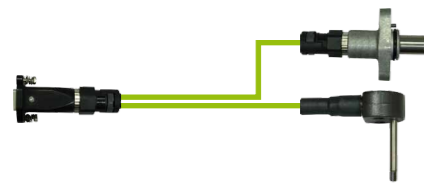

Example:
Temperature sensor + speed sensor
+ cable + connector

On request, we are able to assemble customised cable harnesses to suit your specific requirements. Several sensors (mostly temperature and/or speed sensors), a plug connector of your choice and protective tubing, if necessary, are combined to make a cable harness, thus creating a rugged sensor assembly. Our technicians take measurements on site to ensure optimum adaptation of the cable lengths to the gearbox, engine/motor, etc.

Cabling

Our sensors are always equipped with the cable types specified for the vehicle engineering sector. We apply the following principles to cables in cable harnesses with protective tubing:

- Instead of individual conductors cables are used so that, together with the cable sheathing, a multi-layered protection system is created, thus effectively avoiding water ingress as the result of damage to the protective tubing and cable chafing in the tubing.
- All sensor terminals are led directly to the connector to avoid electrical connections in the protective tubing.

Sensors

Our cable harnesses are predominantly connected to speed and/or temperature sensors. The sensors can be combined in any configuration. You will find further information on speed and temperature sensors in this brochure or we will gladly provide the information on request.

Other peripheries are possible and a meeting can be arranged to discuss them in detail. All our sensors have, of course, been developed in accordance with applicable guidelines and are equipped with standard installation flanges as required in the transport technology applications.

Corrugated tubing for standard applications

As common practice in the sector, we use corrugated tubing for standard vehicle engineering applications to provide adequate mechanical protection in many applications. Further advantages include the low weight and high degree of flexibility for installation.

Special protective tubing under extreme conditions

Our years of experience and our close cooperating with our customers have proven that corrugated tubing cannot adequately protect cabling from stone and ice impact especially on high speed trains, with soiled track beds and under extreme temperatures.

Example:

In harsh winters, snow and ice collect on the corrugated tubing thus drastically increasing the weight. The extremely low temperatures make the material brittle. Mechanical stress such as vibration and shock can easily cause conventional corrugated tubing to break.

To protect our products from such extreme conditions we have developed a special solution, placing us one step ahead of our competitors:

To meet extreme demands we use special protective tubing to optimally protect the cable.

The advantages of this special tubing can be found not only in the tubing itself but also in the water and pressure-tight transitions between the tubing and sensors and connectors. These components must not be subject to torsional stress when installed. For this reason, all sensors can turn through 360°, thus making our cable harnesses very easy to install.

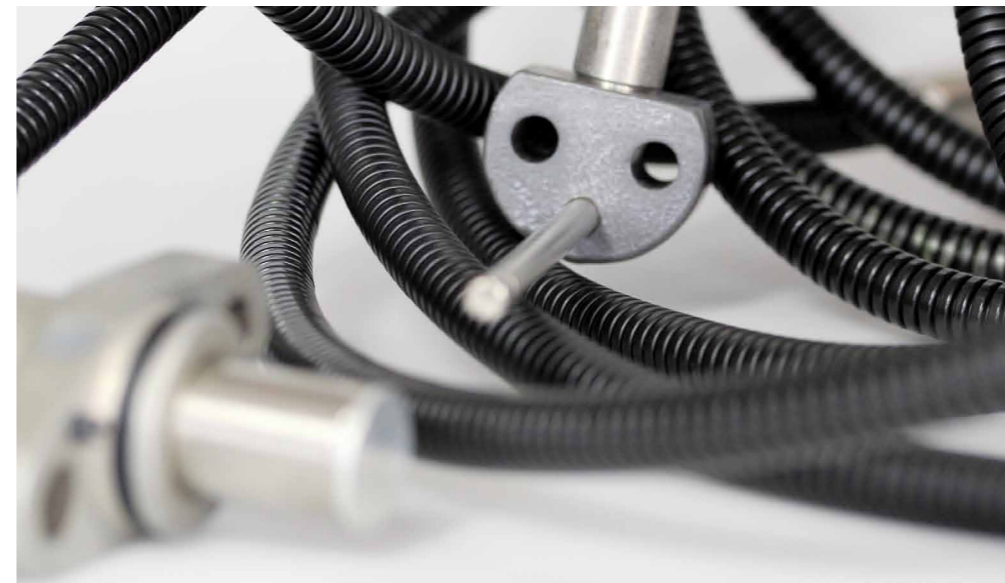

	Corrugated tubing	Special protective tubing
Application	Standard applications	Increased or extreme requirements
Areas of use	Gearboxes, engines, motors, traction control in vehicle engineering, special machine construction, construction machinery, mining	
Regions	Western Europe, USA, India, China	Eastern Europe and China
Use	<ul style="list-style-type: none"> • Metro, trams • Passenger and goods trains 	<ul style="list-style-type: none"> • High speed • Aged, soiled track beds • Exterior (underfloor) • Fire protection – indoors
Material	Polyamide	Rubber with braided lining
Advantages	<ul style="list-style-type: none"> • Inexpensively priced • Low weight • Relatively flexible installation possible 	<ul style="list-style-type: none"> • Outstanding protection against stone and ice impact (mechanical stress) • Excellent temperature characteristics
Temperature characteristics	+++	+++++
Vibration/shock	+++	+++++
Cable	Optionally with or without fire protection certificate	
Fire protection certification	<p>With fire protection certificate: Insufficient protection in low temperature range (< -20 °C)</p> <p>Without fire protection certificate: Adequate protection in low temperature range (currently used for construction machinery (mining))</p>	<p>With fire protection certificate: Excellent protection in low temperature range</p>
Plug connector	We only use high quality connectors of renowned manufacturers	



Speed pick-ups

Speed pick-ups are used to convert rotary motion into electrically proportional square-wave signals where the drive shaft of the speed pick-up is mechanically connected directly to the speed source (e.g. motor, generator). Alternatively, a coupling or a flexible shaft can be used as the connection.

Functional principle

The rotation information of the drive shaft is converted by a Hall switch in the device into a squarewave signal that is proportional to the speed. An integrated signal amplifier makes it available at the output.

	Single-phase; NAD1, NAD2	Two-phase with direction of rotation relay; NADS3
Application	Speed acquisition on engines, machinery and gearboxes	
Housing and mounting	<ul style="list-style-type: none"> • Metal housing – IP67 • Shaft: Slot mounting (NAD1) • Shaft: Blade mounting (NAD2) • Mounting: Screw-in thread M22 x 1.5 	<ul style="list-style-type: none"> • Metal housing – IP66 (plastic terminal box) • Shaft: (Ø 10 mm) for coupling • Mounting: Spigot – Ø 40 x 40 mm
Frequency	0 ... 6000 rpm (0 Hz ... 1500 Hz)	0 ... 6000 rpm (0 Hz ... 6000 Hz)
Connection	Euro M12 x 1	Screw terminals (1.5 mm ²)
Temperature range	-25 °C ... 100 °C	-25 °C ... 85 °C
Special features	<ul style="list-style-type: none"> • Compact design for directly screwing into engine block • Comprehensive range of accessories, as well as matching measuring transducers and limit value switches available • Modular design for special solutions on request 	<ul style="list-style-type: none"> • Two square-wave signals for detecting direction of rotation • Binary direction of rotation signal (relay)

“Substitute for flexible shaft” - RETROFIT

To increase the service life of old machines they are often equipped with modern control components as part of RETROFIT solutions. In connection with new control systems, outdated sensors in particular

often pose problems in terms of reliability, accuracy, signal compatibility as well as signal stability and consequently also need to be replaced. For speed acquisition, a combination of a flexible shaft and

tachogenerator was often used in older systems. Our NAD1 and NAD2 speed pick-ups have been specially developed as a substitute for this component assembly and offers the following advantages:

- Outstanding accuracy and highly stable output signal (square-wave signal) adapted to modern control systems
- Lower procurement costs, decreased susceptibility to faults and longer maintenance intervals by reducing the number of mechanical components
- Directional rotation detection without additional expenditure
- Procurement of spare parts is more reliable, uncomplicated and less costly

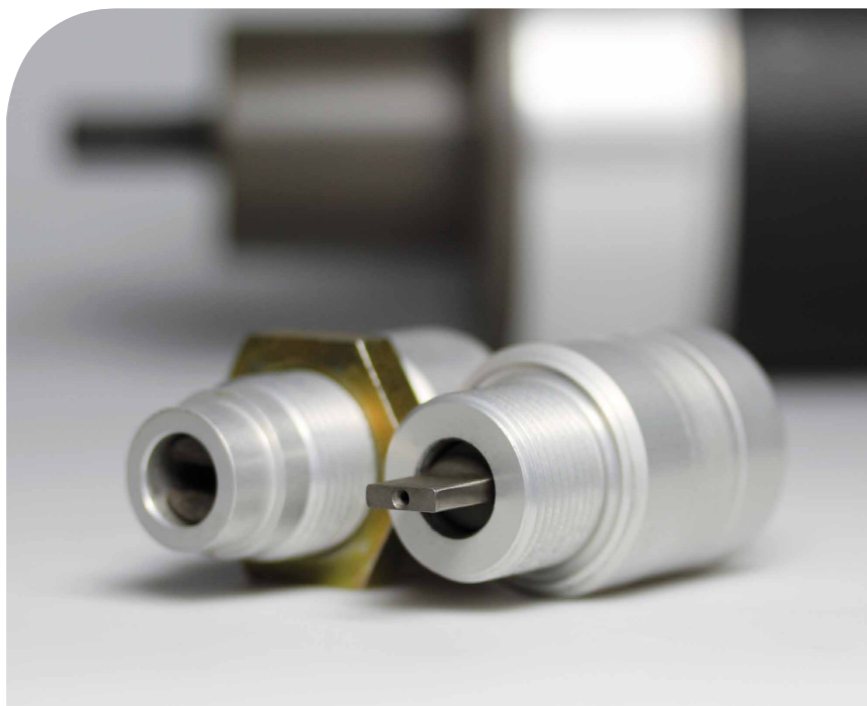

Pressure transducers

Pressure transducers register pressures of liquid and gaseous media and convert the acquired information into linear, proportional, electrical industry standard signals at the output. The devices are characterised by high degree of reliability, sturdy and compact design as well as flexibility in adapting to different measurement tasks.

Their applications include the monitoring of:

- Lubricating oil and fuel pumps on combustion engines
- Hydraulic and pneumatic systems
- Filters, compressors, pressure tanks
- Fill levels in tank systems

Our pressure transducers are available both as screw-in devices as well as surface-mounted devices with holes for individual piping and are suitable for measuring absolute and relative pressures (as from -1 bar).

	PAG8, PAA8	VD6
Application	Registering pressure of liquid and gaseous medium	
Housing and mounting	<ul style="list-style-type: none"> • Cylindrical metal housing*) – IP65/IP67 • For directly screwing into a pressure tank for example • Thread types: G¼, ¼-18 NPT, M14 x 1.5 	<ul style="list-style-type: none"> • Cuboid aluminium housing*) – IP65 • For rigid and flexible piping • Thread types: G¼ female, G½ male
Pressure ranges	Up to 600 bar (relative, absolute); special pressure ranges possible on request	
Electrical connection	<ul style="list-style-type: none"> • Right-angle connector DIN 175301 • Euro plug M12 x 1, cable outlet 	<ul style="list-style-type: none"> • Screw terminals (1.5 mm²)
Output signals	<ul style="list-style-type: none"> • 4 ... 20 mA (2-conductor) • 0 ... 10 V (3-conductor) 	<ul style="list-style-type: none"> • 4 ... 20 mA (2-conductor)
Temperature range	Measured medium temperature -30 °C ... +100 °C	
Special features	Reducers and damping elements available	

*) Parts and housings that come in contact with the measured medium are made from CrNi steel



Rotation angle pick-ups

Our rotation angle pick-ups are used wherever angular positions need to be registered reliably and converted into electrical signals by control systems for status monitoring purposes. The sensors are used, for example, in systems for displaying actual values and limit thresholds. As angle of rotation sensors are mostly installed directly on the bearing-mounted shafts of the objects to be measured and are therefore often difficult to access in such system, we attach particular importance to ensuring our sensors are durable, provide a long service life and are maintenance-free.

Functional principle

In the device, the rotation of the drive shaft is transferred to a precision potentiometer featuring conductive plastics technology, which enables virtually infinite resolution over a service life of more than 10 million shaft rotations. The drive shaft turning through the specified angle range initiates an analogue change in the resistance by the specified ohmic value. These potentiometers are designed as 2-stage or 3-stage units to enable signal evaluation in redundant or galvanically isolated systems. The connections of each potentiometer stage are led outwards for external wiring.



	Series 1; DWA...-1	Series 2; DWA...-2	Series 3; DWA...-3
Application	Registering propeller pitch and rudder position in shipbuilding applications		
Housing and mounting	<ul style="list-style-type: none"> • Metal housing – IP66 • Spigot – Ø 40 x 40 mm • Similar to DIN 5377, connection 2 	<ul style="list-style-type: none"> • Metal housing – IP66 • Spigot – Ø 30 x 30 mm • Similar to DIN 5377, connection 1 	<ul style="list-style-type: none"> • Metal housing – IP66 • Spigot – Ø 40 x 40 mm • Similar to DIN 5377, connection 2
Angle of rotation	Standard: 50°, 70°, 90°, 180°, 240°, 320°		Standard: 90°
	Other ranges on request; 360° rotation possible – no mechanical stop		
Potentiometer and channels	Dual – galvanically isolated	Dual – galvanically isolated	Triple – galvanically isolated
	Resistance – standard: 2 kΩ		1 kΩ
Connection	Terminals	Cables (7 x 0.5 mm ²)	Cables (10 x 0.5 mm ²)
Temperature range	-40 °C ... +70 °C		
Special features	<ul style="list-style-type: none"> • MED (Marine Equipment Directive) certified for rudder blade position display: The complete measurement chain was certified together with our indicators in the NORIMETER product family • Comprehensive range of accessories such as flanges and retaining fixtures as well as matching measuring transducers and limit value switches available • Modular design for special solutions on request 		

Tachogenerators

Our AC tachogenerators are predominantly used wherever operation of indicator and display devices independent of mains power supply is required. These maintenance-free devices are built to be extremely robust, making them ideal for harsh operating conditions. They can be driven either with couplings directly at the rotor shaft or indirectly via friction wheels, belt pulleys, sprockets or flexible shafts.

Functional principle

Tachogenerators operate in accordance with the generator or exciter principle similar to a bicycle dynamo: A permanent magnet rotates in a fixed winding where it induces an AC voltage signal that is proportional to the speed of the drive shaft. This voltage and/or its frequency can be used as measuring variables.

Multiphase AC voltage tachogenerators

Multiphase AC tachogenerators supply two identical, galvanically isolated sinusoidal signals that are electrically offset by 90° with respect to each other. This makes it possible for a downstream evaluation unit to determine direction of rotation.

Tachogenerators with integrated direction of rotation switch

Our devices are available with integrated directional rotation recognition. Depending on the type of device, direction of rotation information can be optionally output as:

- Polarity change of the DC voltage signal
- Floating changeover contact



Tachogenerators; GE / GZ	
Application	Registering speed without auxiliary voltage
Housing	<ul style="list-style-type: none"> • Metal housing – IP65/IP66 • Drive side IP54
Mechanical connection	<ul style="list-style-type: none"> • The connection dimensions (pin/shaft) correspond to DIN specifications • Variable mechanical connections possible
Speed range	Up to max. 6000 rpm (depending on type)
Electrical connection	Tab connector, connection cable, screw terminals in terminal box
Output signals	<ul style="list-style-type: none"> • AC and/or DC voltage output • Various voltage characteristics available
Temperature range	-20 °C ... +80 °C
Special features	<ul style="list-style-type: none"> • Directional rotation recognition possible • Mounting elements such as flanges and holders available • Drive elements such as couplings, belt pulleys or friction wheels available • Powerful for supplying several indicators/evaluators

Irrespective of the speed, a change in direction of rotation is detected as from approx. ¼ turn of the drive shaft. The AC voltage signal can be additionally used for the purpose of evaluating frequency.



Signal processing in detail

Standard devices

Measuring transducers

Limit value switches

Multifunctional devices

Automation systems

(see product brochure
on automation components)

In the field of signal processing, our product portfolio ranges from simple control units such as measuring transducers, limit value switches, isolation amplifiers through multifunctional devices to highly complex automation systems (refer to our product brochures on automation components).

Control units for special applications

Our customers' demanding tasks and varied applications often require individual solutions. We specialise specifically in satisfying these requirements and offer you the following advantages:

- Your new device optimally matched to your specific application
- You only get and pay for the functions you really need
- Interface compatibility with other components possible without the need for additional devices

Our standard devices come with built-in functions that already cover most applications. By the use of innovative technologies and sophisticated concepts we are able to offer you inexpensively priced, high quality products also for your specific objectives. All our devices can be easily adapted to changing conditions or special requirements.

Design according to your requirements:

- Combine functions and interfaces in analogue and digital technology
- Determine input and output signals and their accuracy
- Select housings, mechanical systems, connectors and materials for your device
- Determine the relevant standards and necessary approvals

Our control units of the future

We are constantly improving our sophisticated and well-proven products and concepts. For us, to keep pace with technological development means to recognise today the trends of tomorrow. You, as our customer, are most important because your requirements will become the standards of tomorrow. These are your benefits:

We integrate successful, individual solutions

Cooperating with our customers sheds light on new approaches that we then integrate in our standard products to fine-tune them for their intended application. One efficient product instead of many individual devices – that is our goal.

We incorporate technical innovation in existing products

The use of state-of-the-art electronic components allows us to achieve greater accuracy, improve performance and even develop new additional functions. For this reason we are continually developing our products in line with technological developments while keeping prices virtually constant.

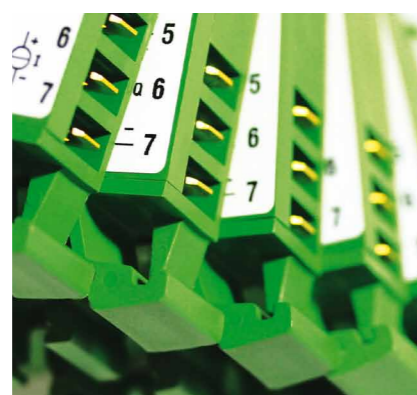
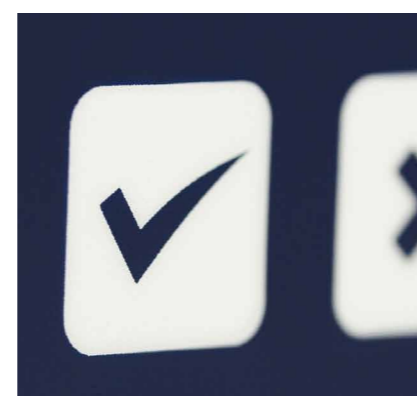

Measuring transducers and limit value switches

Measuring transducers and limit value switches are often used to realise simple monitoring tasks. They provide galvanic isolation, signal conversion and conditioning. They are used wherever the most demanding requirements are made in terms of reliability and long service life. The compact devices can be installed both in central control cabinets as well as directly in the vicinity of motors. As our measuring transducers and limit value switches are often used together they are housed in a single plastic enclosure. The inputs of our devices are perfectly adapted to our sensors.

Measuring transducers

Measuring transducers convert measured electrical input variables (mainly sensor signals) into standardised output signals proportional to the sensor signal or corresponding field bus protocols. Measuring transducers can be used, for example, to adapt sensors to downstream controllers, achieve galvanic isolation and transfer weak, susceptible sensor signals over longer distances.

Special designs for special applications

We develop devices with special functions for special applications such as a measuring transducer with integrated error correction for railway wheel wear. The device is suitable for all commonly used wheel diameters. The drum scale for setting the limit is protected by a sealed cover.

	Measuring transducer - Series 5; VF / VP / VT	Limit value switch - Series 5; RF / RG / RH / RI / RP / RT / RW
Application	Signal conditioning, signal conversion, galvanic isolation	Limit monitoring, galvanic isolation
Enclosure and dimensions	<ul style="list-style-type: none"> • Plastic enclosure for installation on mounting rail, IP20 • 70 mm x 46 mm x 17.5 mm 	
Connection	Gold-plated tab connector	
Galvanic isolation	Operating voltage / inputs and outputs	Supply voltage / inputs / outputs
Input signal	Frequency: Square-wave, sine, three-phase generator Temperature: Pt100/Pt1000, thermocouple (J, K)	Standard: UDC, UAC, I Frequency: Square-wave, sine, three-phase generator Temperature: Pt100/Pt1000, thermocouple (J, K), NTC
	<ul style="list-style-type: none"> • Internal comparator for thermocouple temperature compensation • Frequency ranges can be adapted to customer requirements 	
Output signal	<ul style="list-style-type: none"> • 0 ... 10 V, 2 ... 10 V (short-circuit-proof) • 0 ... 20 mA, 4 ... 20 mA 	<ul style="list-style-type: none"> • Floating output contact as changeover contact, NC contact, NO contact
Temperature range	-20 °C ... +70 °C	
Special features	<ul style="list-style-type: none"> • LED operating status indicator • Short-circuit-proof inputs and outputs • Open circuit and/or short-circuit monitoring • Matching NORIS sensors 	



Limit value switches

Limit value switches are used for the purpose of monitoring measured variables. The built-in relay (changeover contact) switches when the actual value of the measured signal reaches the set threshold. In this way statuses can be monitored by downstream evaluation electronics or switching operation can be implemented directly.

Closed-circuit devices	Open-circuit devices
Threshold not reached - relay active	Threshold not reached - relay not active
Threshold reached - relay not active	Threshold reached - relay active

Special designs for special applications

We develop devices with special functions for special applications such as a limit value switch with test function: A higher measuring signal is simulated by pressing an integrated button for the purpose of testing the monitoring system without having to operate the system in the critical range.

Parametrisation

The switching thresholds are set mechanically by means of a drum scale (potentiometric). A sealed cover is available to prevent the setting being changed inadvertently or by unauthorised persons.

Multifunctional devices

Our multifunctional devices are a combination of measuring transducers and switch-gear. They are used wherever several variables are to be monitored with one device, special measurements such as slip and offset measurement are performed and flexible parametrisation is required.



Solution-orientated multifunctional devices

Our multifunctional devices are based on solution-orientated design. Recurring applications that to date had to be realised by several individual components are now performed by one single device. To this end we equip such devices with functions that you require for your specific applications.

The benefits for you are:

- Optimum price/performance ratio by adapting the scope of electronics, interfaces and functions to specific application requirements
- Error minimisation in installation and servicing
- Menu-controlled parametrisation for maximum ease of operation

Speed evaluation with "NORISPEED"

NORISPEED is an evaluation unit for connection of up to two speed sensors. The properties of a measuring transducer and of a limit value switch are combined and evaluations based on the acquired measured data are made available via switched outputs or standard signal outputs. The user can set up the device directly with the aid of menu-controlled navigation and an integrated LC display. Current measured values can be shown on the display, making them easy to check.

Applications

- Speed measurement and conversion to standard signals
- Directional rotation recognition in reversing gearbox systems
- Speed monitoring or engine protection (nominal speed and overspeed detection or drive shutdown with signalling to a remote station, e.g. to a safety system)
- Gearbox monitoring by means of slip measurement

NORISPEED; FMN6	
Application	Evaluation of up to two speed sensors
Housing	Sturdy aluminium housing for installation on mounting rail
Connection	Connector with spring-loaded contacts
Inputs/signals	<ul style="list-style-type: none"> • Two galvanically isolated frequency inputs (1...12,000 Hz) • Square-wave signal (NORIS standard signal, PNP, NPN)
Outputs/signals	<ul style="list-style-type: none"> • Two galvanically isolated standard signal outputs, parametrisable as 0 ... 5 V, 0 ... 10 V, 2 ... 10 V, +/-5 V, +/-10 V, 0 ... 20 mA and 4 ... 20 mA outputs • Six relay outputs with working contacts (max. 2 A) • All outputs are short-circuit and overvoltage-proof
Display/LED	<ul style="list-style-type: none"> • Measured value display and menu prompting on integrated display • LED operating status indicators
Temperature range	-20 °C ... +70 °C
Special features	Wire break detection (speed sensors)

Application examples

Speed measurement

Two independent speeds (up to 10,000 rpm) can be registered and converted into proportional analogue signals. The digital outputs can be individually designated to the two frequency inputs and assigned different functions (e.g. limit monitoring).

Directional rotation recognition

The signals of two radially offset speed sensors or those of a dual sensor are evaluated in the device and sent to two digital outputs. All analogue and digital outputs are freely programmable in this mode.

Slip measurement

Two speeds are measured and evaluated with mechanical, parametrisable reference to each other. The freely programmable outputs can forward the speed signals to a downstream evaluation unit. The digital outputs can be used for status messages and limit monitoring purposes.

Offset measurement

Offset measurement refers the measured speed to a set target speed and the result is output as an analogue value (via analogue outputs), e.g. to precisely monitor the target speed of a generator. The scaling of the speed deviation is freely programmable. The digital outputs can be used for status messages and limit monitoring purposes.

Measured value conversion

The frequency signal can be converted into standard signals (see table). In connection with directional rotation recognition, the signal range can be split for anticlockwise and clockwise rotation.

Visualisation in detail

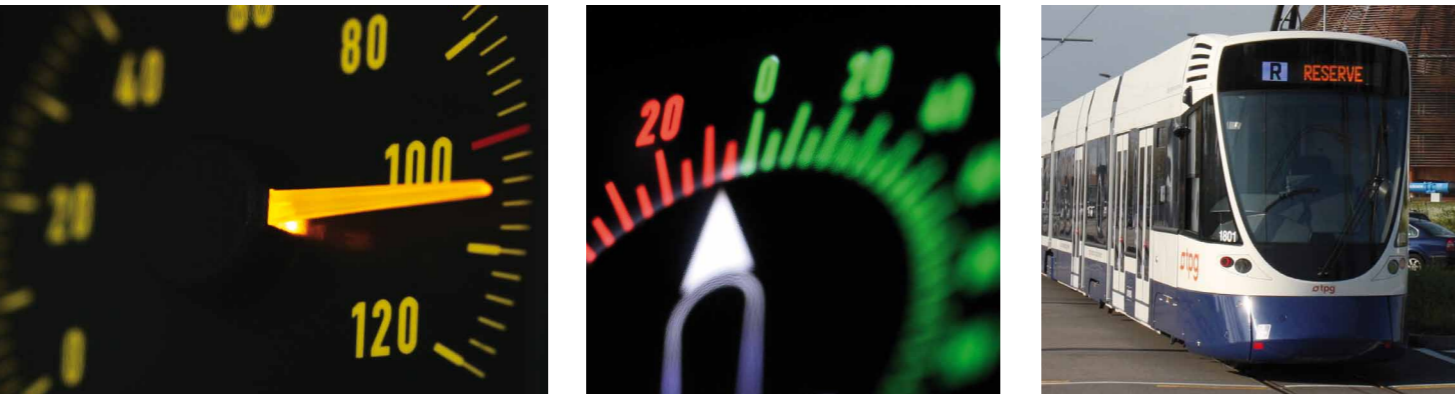

© Stadler Altenrhein AG

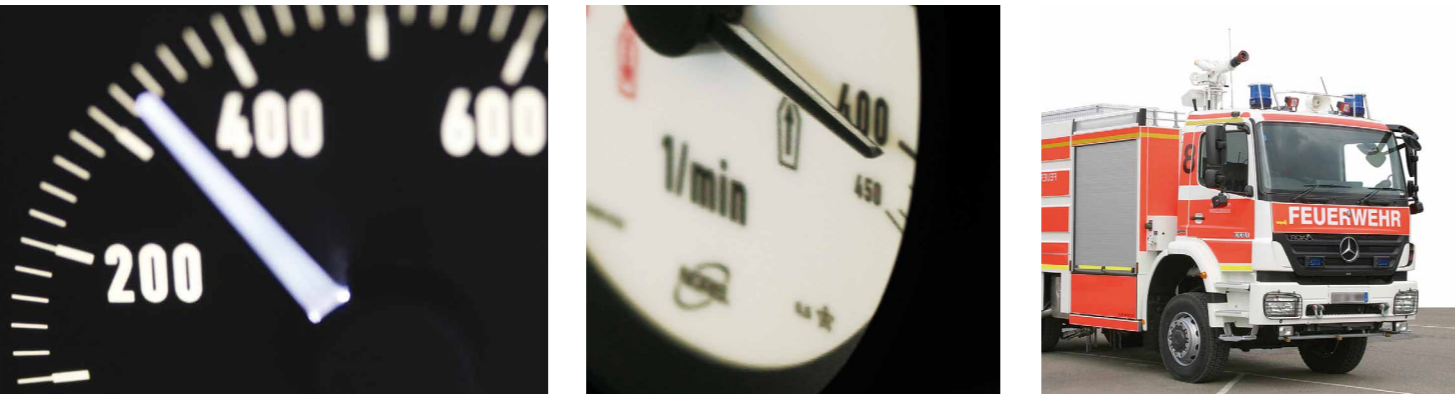

© Ziegler



© Voith

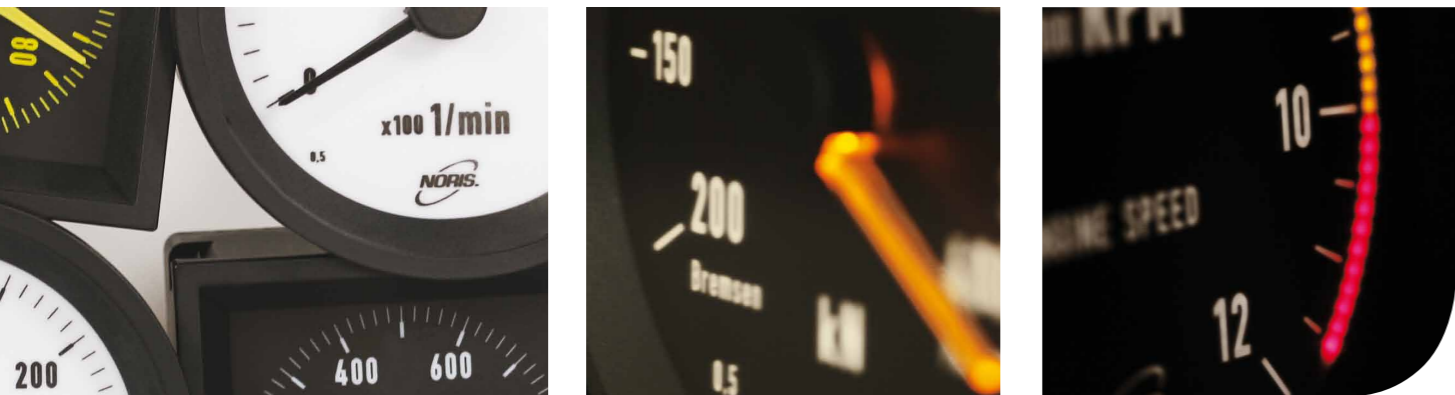

Whether on the bridge of a luxury yacht, river boat or of an oil tanker; whether on open deck or in the engine control room; whether in control panels or directly in the vicinity of engines; whether speed, rudder position, propeller pitch, temperature, pressure or wind direction; whether in shipbuilding, transport technology or industry; whether in Europe, Asia or America: Our indicators are used in a vast number of varied applications throughout the world. This is thanks to the robust design and reliability of our products as well as their adaptability to any application.

Indicators for special applications

The modular design of our indicators allows us to easily customise special solutions. This requires a well-conceived housing design in standard sizes and a controller-based stepping-motor and lighting concept. You can choose from a large selection of standard scales. On request we will adapt the scales to your specific application or design them to your specifications.

NORIS visualisation in the future

Our aim is to offer technical progress of the highest quality at an attractive price also in the future. To this end we are focussing on:

"Intelligent" indicators

Today's indicators have to do more than simply display measured data. By combining the indicator function with other functions such as those of a measuring transducer and/or limit value switch, the number of components as well as system costs can be greatly reduced. We are developing new solutions in this field.

GUI (Graphical User Interfaces)

The visualisation of measured data with graphical user interfaces will soon be common place in many applications. We are developing customised products in this field. The advantages of devices with this technology include:

- Adaptation of the GUI to measured variables, scales, colours, configuration and parametrisation for maximum flexibility
- Display of additional important information for the user
- Integrated control functions are possible

Standard indicators

- Indicators with moving-coil
- Indicators with stepping-motor drive
- Stepping-motor indicator (360° indicator)
- Display solutions as part of automation and safety engineering

Analogue indicators

Our analogue indicators feature stepping-motor technology or are equipped with a moving-coil element. They are primarily used wherever great demands are placed on durability and reliability. They are largely unaffected by harsh ambient conditions and thermal extremes. Long lifetime and easy readable values even in case of direct sunlight are further advantages compared to indicators with displays.



Main properties of stepping-motor indicators - NORIMETER

Functionalities

- MIN-MAX value reading, extreme value monitoring
- Optional binary input and/or switched output (limit value switches)
- Integrated status LED (e.g. for exceeding limits)

Lighting

- Innovative LED lighting concept for bright, uniform scale and optional pointer lighting
- The basic brightness setting (pointer and scale separate) can be adapted to adjacent devices and ambient conditions

360° indicators

Our 360° indicators that are used in connection with azipods are equipped with dials instead of pointers. The indicator or dial performs automatic travel optimisation.

MED (Marine Equipment Directive)

An MED certificate (European Marine Equipment Directive) is generally required for use of indicators for ship navigation (propeller pitch, speed, rudder position). For this reason, our NORIMETER stepping-motor indicators have been approved together with our DWA series rotation angle pick-ups and measuring amplifiers as a complete measuring chain in order to comply with all necessary criteria.

Analogue indicators	
Illuminated scale: white (standard)	Scale labelling: black Pointer: black, unlit
Illuminated scale: black	Scale labelling: colour specified by customer Illuminated pointer: white, red when lit (standard); optionally illuminated yellow or red
Extras	Customer logo, different colours, spread, scales for indicators turning anticlockwise, double scales on multiple indicators

“Intelligent” indicators

In addition to simply showing measured values, for us the term “intelligent” indicator means providing extended functions, which enable the indicator to convert measured values or evaluate signals. These devices were developed as a solution to specific problems, thus avoiding unnecessary costs.

NORIMETER 3 - Indicator with integrated directional rotation detection

Two speed sensors or a dual sensor (two sensors in one enclosure) can be connected to this device without the need for additional electronics. The indicator identifies the direction of rotation based on the phase angle of both sensor signals and shows it together with the speed on the scale (right/left stop).

Special solutions

Our indicators can of course be adapted to specific customer requirements. You have the choice to:

- Select the colour of the scale dial from a range of colours
- Define the colour of the scale
- Select the colour of the scale and pointer lighting
- Have customised scale and zero point calibration

More extensive changes are also possible. At various points we have already prepared appropriate concepts in advance and hope we have sparked an interest.

- Indicator with integrated display
- 96 step LED indicators in different colours (can also be combined with stepping-motor indicator)
- Two-pointer devices
- Input and output expansions

Scales and pointers

The “face” of any indicator is its scale. This feature gives every indicator its individual character and personal touch. We have available a large selection of standard scales or if necessary we can also create special scales that precisely conform to your specific requirements - simply talk to us.

If not otherwise specified, the scale labelling and graduation will conform to DIN 43802 and DIN 43780.

	Indicator with moving-coil element; R / RQ	Indicator with stepper motor drive; NIR/NIQ
Application	Low cost; no auxiliary voltage required	Universal
Size *)	Round: 60, 80, 100, 130, 160; square: 72, 96, 144	
Housing	Glass-fibre reinforced plastic or metal housing	
Protection class	Depending on housing – front: up to IP66/IP67; connection side: IP30	
Accuracy class	0,5; 1.0; 1.5 depending on measuring system	< 0.5
Indicator angle	0° ... 240°	0° ... 300° (pointer); 0° ... 360° (dial)
Illumination	Lamps, dimmable LED	Dimmable LED; illuminated pointer
Inputs	U, I, frequency, resistive inputs	U, I, frequency, resistive inputs (galvanically isolated)
Electrical connection	Terminals / various connectors	8-pin or 9-pin Phoenix connector
Temperature range	-25 °C ... +70 °C	
Application and special features	<ul style="list-style-type: none"> • Generally more cost-effective than stepping-motor indicators • A supply voltage is not absolutely necessary • Exceptional electrical robustness thanks to minimal circuitry • No electromagnetic radiation 	<ul style="list-style-type: none"> • Precision measured value approach and hold • Outstanding mechanical robustness: Not influenced by bearing friction and transverse acceleration from high stepper motor actuating forces • Line compensation possible • Auxiliary energy and sensor failure monitoring function (live zero) • Automatic zero calibration after switch-on • Scale spread, selectable anticlockwise rotation and zero point position • Independent pointer position feedback • Operation in any position

*) The dimensions of the housings and control panel apertures conform to applicable standards.

Functional principle and design of the stepping-motor indicator - NORIMETER

Our analogue indicators with integrated stepper motor technology are reliable over a long service life. Measured values are digitised by an A/D converter and shown by means of a processor-controlled, high resolution stepper motor with illuminated plastic pointer on an individually configurable scale. The combination of high quality components and materials with a sophisticated software system ensures maximum accuracy and flexibility. The high EMC protection class as well as the immunity to shock and vibration as stipulated by transport technology and most ship classification bodies enable continuous operation under increased mechanical stress conditions such as direct installation on a motor/engine.



NORIS Automation GmbH
Muggenhofer Str. 95
90429 Nuremberg
Germany

Phone: +49 911 3201-0
Fax: +49 911 3201-150
info@noris-group.com
www.noris-group.com

■ Nuremberg ■ Rostock ■ Rotterdam ■ Singapore ■ Shanghai